



ASSEMBLY INSTRUCTIONS

D6000 Rally Picnic Table



anovafurnishings.com
888.535.5005 tel

TOOLS NEEDED:

- 1/2" Open-end or Box-end Wrench
- 9/16" Open-end or Box-end Wrench
- 5/8" Open-End or Box-end Wrench
- Ratchet with 1/2" Socket
- Ratchet with 9/16" Socket
- Level

ASSEMBLY HARDWARE:

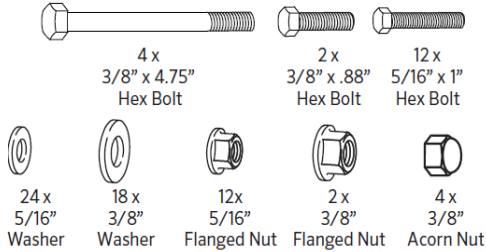

BENCH COMPONENTS:

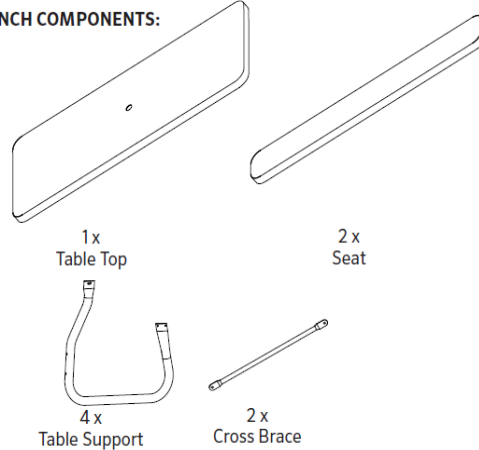

ASSEMBLY:

The assembly is a two-person operation.

1. Inspect the shipping container contents for damage and to determine that all components and hardware are present.

2. Place the Table Top upside down on the shipping packaging or other soft surface to avoid scratching the product. Locate one of the Supports and position it at the mounting hole near the end of the Table Top.

3. Align the mounting hole in the Support with the hole in the bracket on the end of the Table Top. Install a Washer onto one of the 5/16" Hex Bolts and insert the Bolt through the mounting holes in both parts, with the Bolt head on the outside surface of the Support. Install a Washer and Flanged Nut on the end of the Bolt.

NOTE: Installing the Bolt in this direction reduces the risk of scratching during use.

4. Leave the hardware finger tight so that adjustments can be made during assembly and leveling.

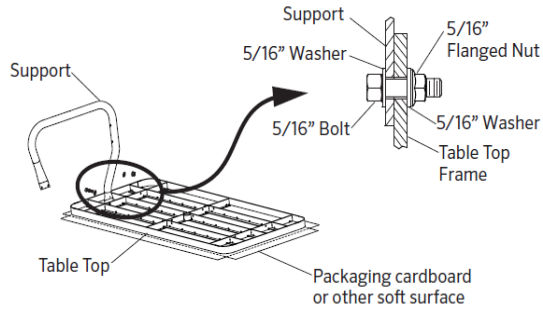

5. Place a 3/8" Washer on one of the long 3/8" Hex Bolts. Locate one of the Cross Braces and position it so that the mounting hole in one end aligns with the lower mounting hole in the center of the Support. Insert the Bolt through the Support and Cross Brace.

6. Place a 3/8" Washer on another one of the long 3/8" Hex Bolts and insert the Bolt through the upper hole in the support. Place three of the 3/8" Washers on the end of the Bolt to act as spacers.

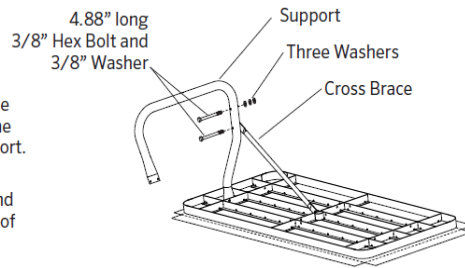

7. Select one of the remaining Supports and position it so that the ends of the long Bolts in the secured Support can be inserted into the appropriate holes in the Support in hand.

When the Bolt ends emerge through the support, place a 3/8" Washer and an Acorn Nut on the ends of the Bolts and tighten finger tight.

Insert a 5/16" Bolt with Washer through the mounting holes in the end of the Support and the Table Top frame. Secure it with a Washer and Flanged Nut. Leave the fastener finger tight until the assembly is complete.

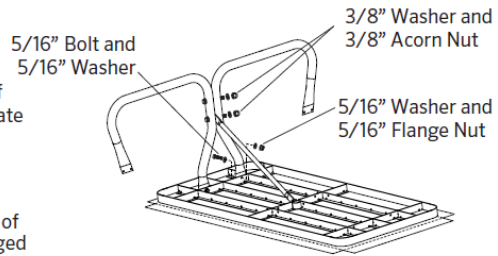

8. Position the other end of the Cross Brace so the mounting hole aligns with the hole near the center of the Table Top frame. Install a 3/8" Bolt with 3/8" Washer through the Cross Brace and the Table Top frame and install a Washer and Flanged Nut on the end of the Bolt. Again, leave the hardware finger tight.

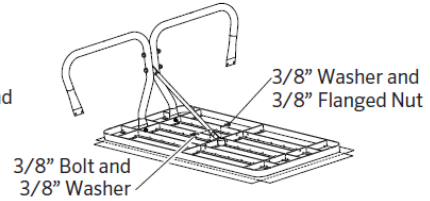

9. Assemble the remaining pair of Supports and Cross Brace to the other end of the Table Top in the same manner.

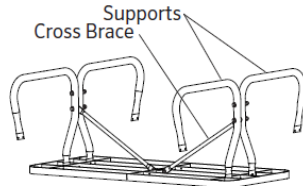

10. Locate one of the Seats and position it near the Support ends. Line up the mounting holes in the Seat with the mounting holes in the Support ends. Insert a 5/16" Bolt with Washer through the each of the sets of mounting holes. Place a Washer and 5/16" Flanged Nut on each of the Bolts and tighten finger tight.

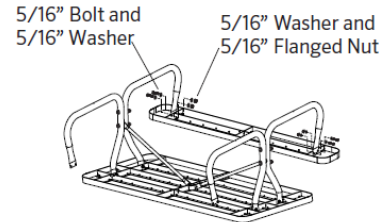

11. Repeat this step for the Seat on the other side of the Table.

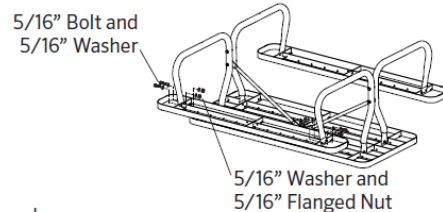

12. Turn the table right side up and tighten all hardware while checking with a Level.
13. Move the assembled Table to the desired location.
14. Retighten hardware two weeks after initial assembly.



- WARNING**
- Furniture must not be used other than for its intended purpose and should be inspected regularly for loose, missing, or broken hardware, and general instability.
 - Furniture that is damaged or appears to be unstable must be removed from service and be repaired or replaced.
 - Repairs must be made using only factory authorized parts and methods.

CARE AND MAINTENANCE

- Do not drag the assembled unit across any surface.
- This product requires only periodic cleaning with a sponge and a solution of mild detergent and water to remove surface dirt. Do not clean with a solvent or petroleum based products.