



ASSEMBLY INSTRUCTIONS

3-Seat Square ADA Tables

F1307- 3-Seat Table with Rolled Edge Seats

F1308- 3-Seat Table with Traditional Edge Seats

anovafurnishings.com
888.535.5005 tel

TOOLS NEEDED:

- Ratchet with 1/2" socket
- 1/2" Open end or box end wrench
- Rubber mallet



F1307



F1308

TABLE COMPONENTS:

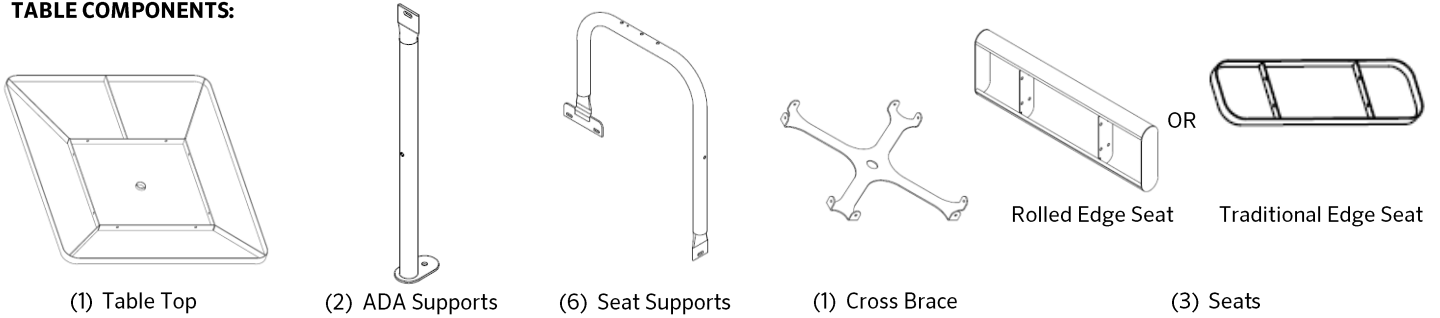

ASSEMBLY HARDWARE: All hardware is stainless steel; extra hardware may be included.



ASSEMBLY:

The assembly is a two-person operation.

1. Inspect the shipping container contents for damage and to determine that all components and hardware are present.
2. Assemble the table over the shipping packaging or padded work area to avoid scratching the product.

Note: Before assembling the nuts to the bolts, it is recommended that a light oil or petroleum jelly be applied to the screw threads.

3. Place the table top upside down on the shipping cardboard or other soft surface. Note the location of the additional table top frame support on the underside of the table top.

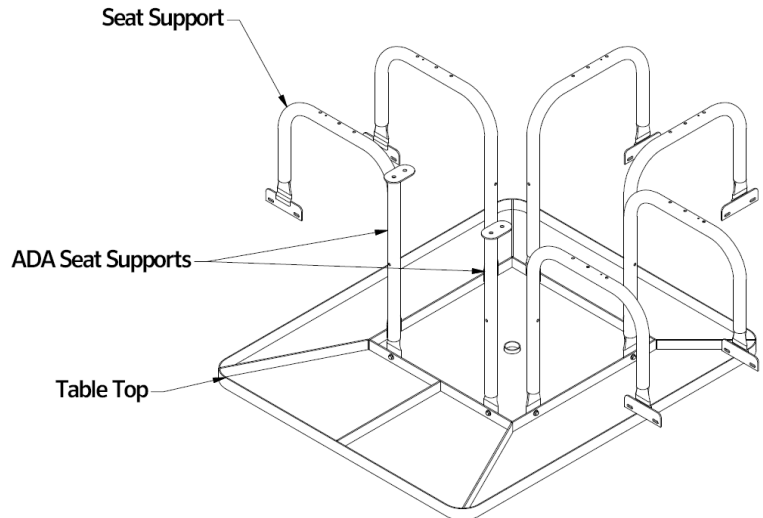

- The ADA supports attach to the table top frame on the side with the additional table top frame support. Position one of the supports next to the table top mounting flange. Align the mounting hole in the support with the mounting hole in the table top flange. Install a 5/16" flat washer on one of the 5/16" x 1 1/4" hex head bolts and insert the bolt through the mounting hole in the table top mounting flange and into the mounting hole in the support. Place a 5/16" flat washer and 5/16" Nylock nut on the end of the bolt and tighten finger tight. Leave bolt and nut finger tight so that adjustments can be made during assembly.

Install the remaining ADA support in the same manner to the same side of table on second table top mounting flange.

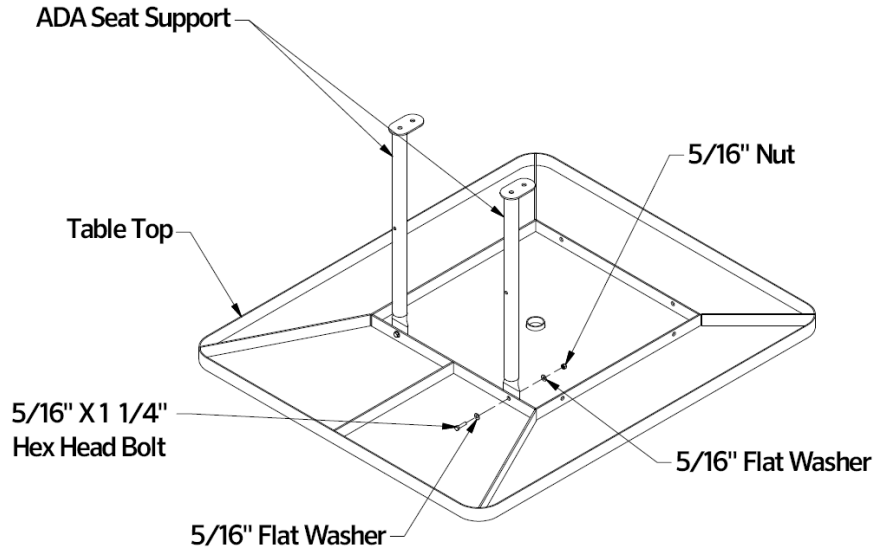

- The seat supports attach to the remaining three sides of the table top frame (two per side). Position one of the seat supports next to the mounting flange of the table top. Align the mounting hole in the seat support with the mounting hole in the table top flange. Install a 5/16" flat washer on one of the 5/16" x 1 1/4" hex head bolts and insert the bolt through the mounting hole in the table top mounting flange and into the mounting hole in the seat support. Place a 5/16" flat washer and 5/16" Nylock nut on the end of the bolt and tighten finger tight. Leave the bolt and nut finger tight.

Install the remaining five seat supports in the same manner.

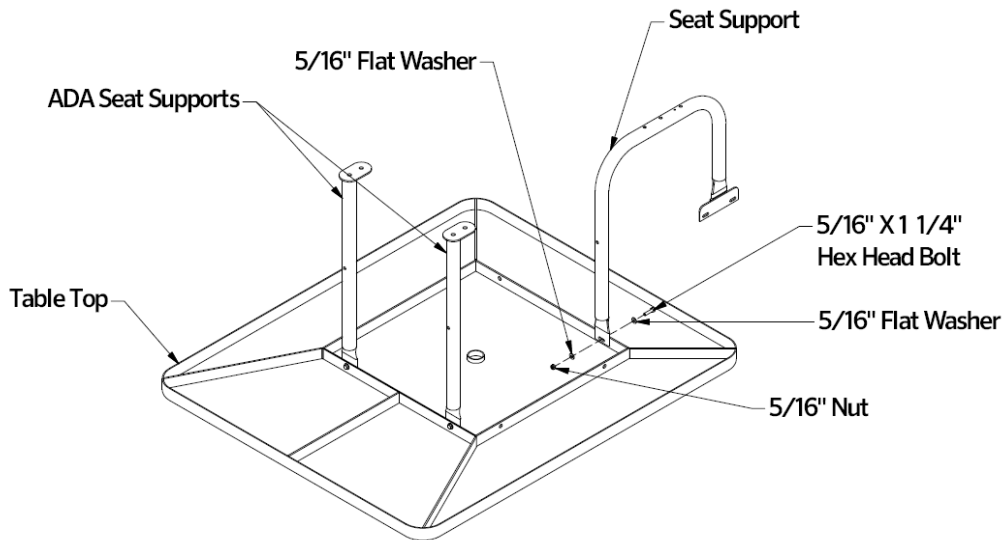

6. Locate the cross brace and position it in the center of the seat supports so that the mounting holes in the brace line up with the mounting holes in the supports. Place a 5/16" flat washer on the end of one of the 5/16" x 2 1/4" hex head bolts and insert the bolt through the support mounting hole and through the matching hole in the cross brace. Fasten the bolt using a 5/16" flat washer and a 5/16" Nylock nut. Leave the bolt and nut finger tight.

Repeat this for the remaining cross brace mounting holes.

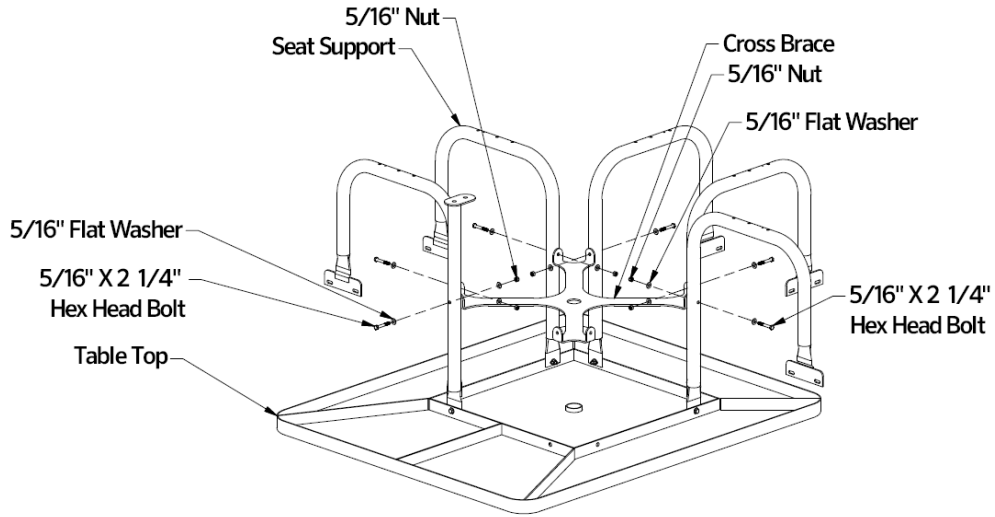

Some Seat Supports Removed For Clarity

7. After the cross brace is installed, locate the plastic plugs and install them in the inside and outside holes on the bottom of the seat supports. Use the rubber mallet to set them if necessary.

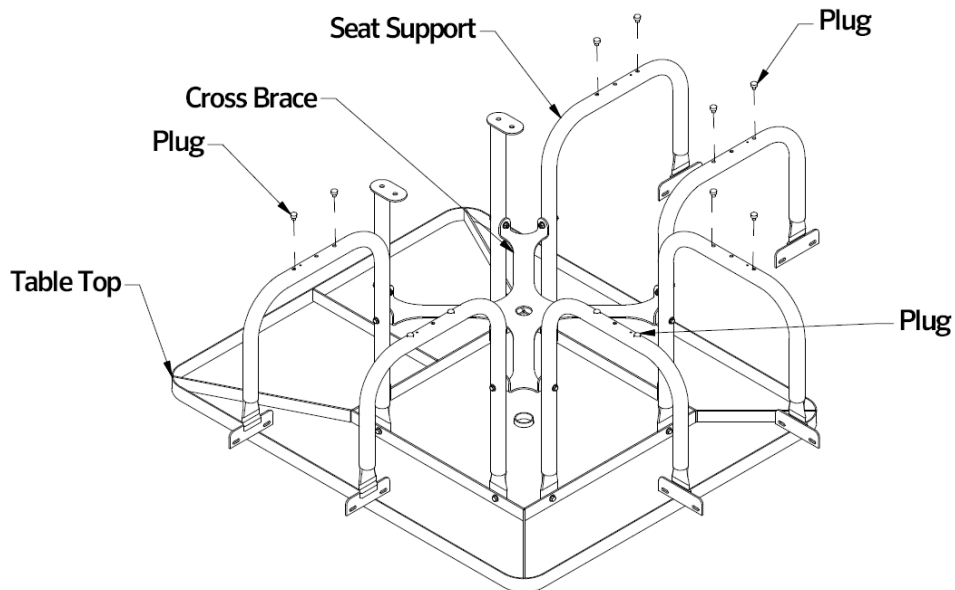

8. Turn the table right side up.

Position one of the seats (rolled edge or traditional edge) over a pair of the seat supports with the seat mounting brackets positioned to the inside of the seat supports. Place a 5/16" flat washer on the end of one of the 5/16" x 1 1/4" hex head bolts and insert the bolt through one of the support mounting holes and through the matching hole in the seat mounting bracket. Fasten the bolt using a 5/16" flat washer and 5/16" Nylock nut. Leave the bolt and nut finger tight. Repeat this for the second seat/support mounting hole.

Install the remaining two seats in the same manner.

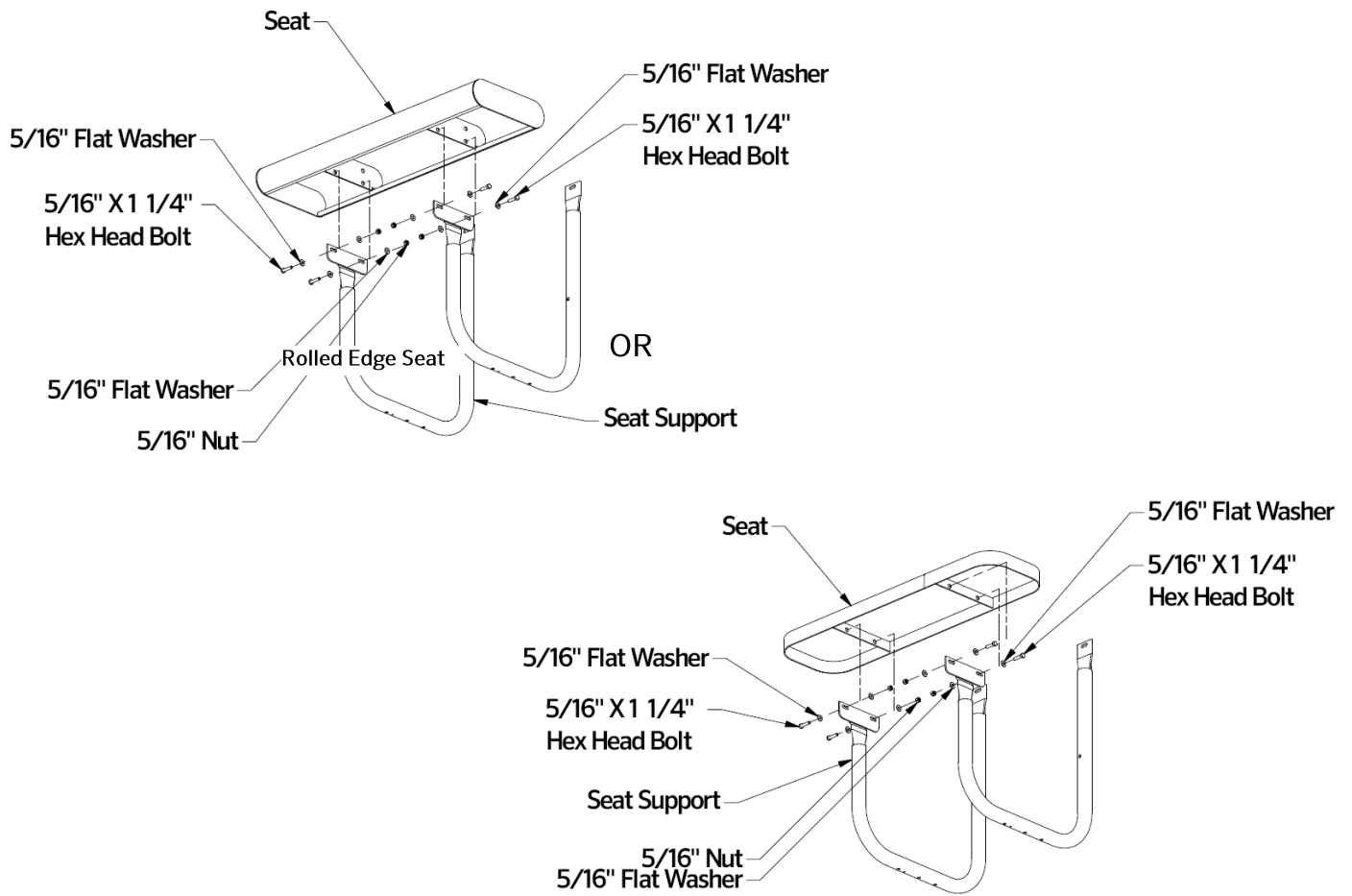

9. Level the seats and table top while tightening all of the hardware.

- Place the tube clamps on the seat legs opposite to the ADA end of the table as shown.

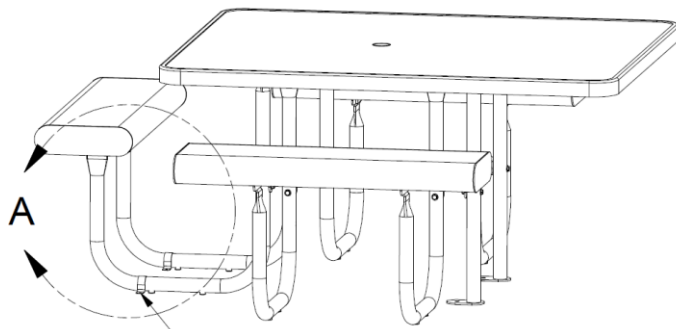

NOTE:
Snap Foot Clamps on these set of
Legs, opposite to the ADA end of Table.

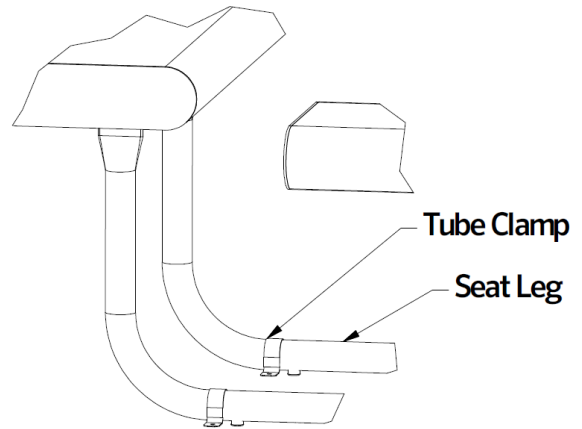

- Move the table to the location where it will be used.
Note: Tables must be surface mounted for stability and to comply with warranty and Federal ADA regulations.
- After two weeks, retighten all hardware.



WARNING

- Furniture must not be used other than for its intended purpose and should be inspected regularly for loose, missing, or broken hardware, and general instability.
- Furniture that is damaged or appears to be unstable must be removed from service and be repaired or replaced.
- Repairs must be made using only factory authorized parts and methods.

**CARE AND
MAINTENANCE**

- Do not drag the assembled unit across any surface.
This product requires periodic cleaning with a sponge and a solution of mild detergent and water to remove surface dirt. Do not clean with a solvent or petroleum based products.